

# HC Bridge SRC

Bulk AoIP format and sample rate conversion

Solid State Logic

OXFORD • ENGLAND



# HC Bridge sample rate conversion

HC Bridge SRC provides 256 bi-directional channels of sample rate conversion for AoIP networks. HC Bridge SRC facilitates connecting audio between devices running at different sample rates or in different clock domains on Dante (48 kHz and 96 kHz), AES67 or ST 2110-30 networks.

The two network connections can be to physically or virtually separate networks, providing control isolation between two sets of equipment where an AoIP discovery and control 'firewall' is required.

An HC Bridge SRC includes 2 HC cards, each providing 256 Tx and 256 Rx channels at 48 kHz or 96 kHz, with 128 Tx and 128 Rx streams at both sample rates. Sample rate conversion can be disabled if not required.

An alternate HC Bridge configuration without sample rate converters is available with higher channel capacity at 48 kHz. An HC Bridge includes 2 HC cards, each provides 512 Tx and 512 Rx channels at 48 kHz, 256 Tx and 256 Rx channels at 96 kHz, with 128 Tx and 128 Rx streams at both sample rates.

Each card includes a redundant pair of SFP cages for 1GbE RJ45, multi-mode fibre or single-mode fibre Dante/AoIP connectivity.



### HC Bridge SRC key features

- Standalone sample rate conversion of Dante and AoIP sources between two sample rates or clock domains
- AoIP discovery and control 'firewall' between physically or virtually separate networks
- 12 pairs of GPIO for use with SSL System T consoles
- Redundant PSUs and Dante/AoIP network connections
- Front facing network connections
- Rear facing HC Link and GPIO connections



HC bridge SRC can be used in many applications, a selection of which are outlined here. This is not an extensive list of every possibility:

### Standalone device

As a standalone device providing conversion, or control and discovery separation between two networks. The serial audio on the rear of the unit is looped by a fibre cable (or cables) between HC Link 1 and HC Link 2. Four fibre SFPs and two duplex fibre cables will provide connection redundancy.

As a standalone device the unit can be used with or without an SSL console.

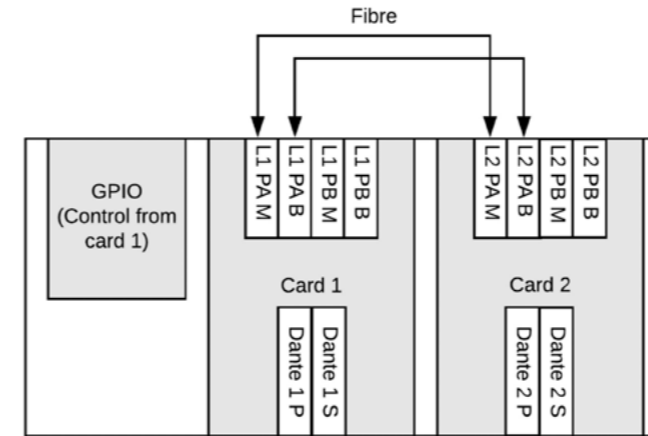

### OB truck Dante-to-Dante 'firewall'

With the increased use of Dante on both OB trucks and festival/event infrastructure, taking a 'network split' from the stage is an attractive prospect for a broadcast mix. A Dante or network split is similar to a MADI split, offering space and cost efficiencies above deploying additional analogue stage-racks and mic splitters. Sample rate conversion allows both systems to use independent clock sources. Physically separating the networks across the HC Bridge allows each team to safely share audio signals without exposing their network to the other side, preventing accidental or malicious changes on the other network.

### 48 kHz and 96 kHz bridge

If a system requires the use of both sample rates on the same network, a looped back unit on the network provides a bulk method to share audio between the different devices. Dante can support multiple sample rates on the same network but only devices of the same sample rate can have audio connected between them. There are examples of this requirement across live touring, fixed installation and music broadcast, using both SSL consoles and other manufacturers' consoles.

### Dante ST 2110-30 converter

SSL System T, SSL Live consoles and Network I/O support Dante and ST 2110 or AES67 on the same hardware at the same time. Standalone conversion between Dante and ST 2110 is not required.

However, for some installations it is useful to separate the audio (Dante) and the video centric (ST 2110) infrastructure, keeping access to these signals separate. This provides the benefits of ST 2110 when working with audio alongside video, in conjunction with the advantages of automatic stream creation using the Dante API for audio centric work-flows, particularly where mono audio routing is required.

Used as a Dante ST 2110-30 converter an HC bridge is analogous to an SDI or MADI connection between an audio and video router in a baseband system. As with many infrastructure design choices, the total number of simultaneously used channels and the intended ability to make changes – or not – factor into connectivity choices. An HC Bridge SRC or an HC Bridge can be used as a Dante and ST 2110-30 (level A, B and C) converter.

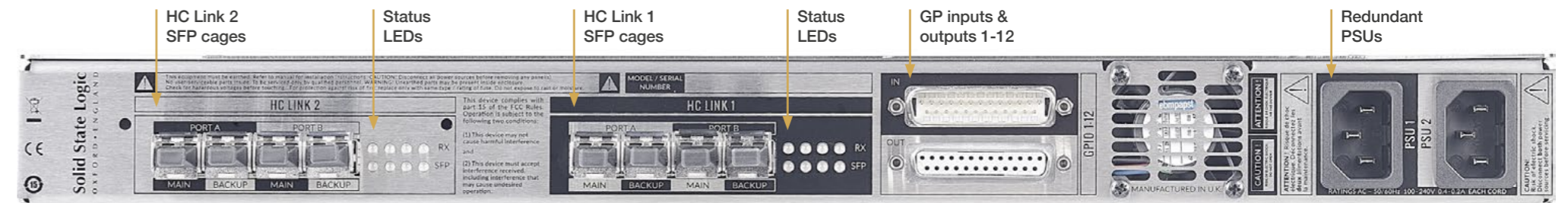

## Product information

Partcode	Description	Note
726932X1	NET I/O HC Bridge	No SFPs included
726933X1	NET I/O HC Bridge SRC	No SFPs included
<b>SFPs for Dante/AoIP connection (four per unit required)</b>		
32SPERG2	SFP RJ-45	
32SPMLG2	SFP LC Multimode	
32SPSLG2	SFP LC Singlemode	
<b>SFPs for Looped Fibre connection (four per unit for fibre redundancy)</b>		
32SPMLDB	SFP LC Multimode	
32SPGLDB	SFP LC Singlemode	

Physical Specification	
Height	1RU, 44.5mm (1.75")
Width	483mm (19")
Depth	340mm (13.4")
Weight	4.5kg

### AoIP support:

Dante, AES67 RTP streams. PTPv1 & PTPv2 (AES67 profile). SAP/SDP for AES67.

Management from Dante Domain Manager for ST 2110-30 streams (level A, B and C). ST 2022-7. PTPv2 (ST 2059-2 and manually editable profile)

# Solid State Logic

O X F O R D • E N G L A N D

International HQ: Begbroke, Oxford, OX5 1RU, England

Tel. +44 (0)1865 842300 · sales@solidstatellogic.com · www.solidstatellogic.com